

*add new tech to your business!*

# Flexible Solution for Power Line Communications

Metering Europe 2008

Amsterdam, 23<sup>rd</sup> of September 2008

Serghei Druta



# PLC in current AMI

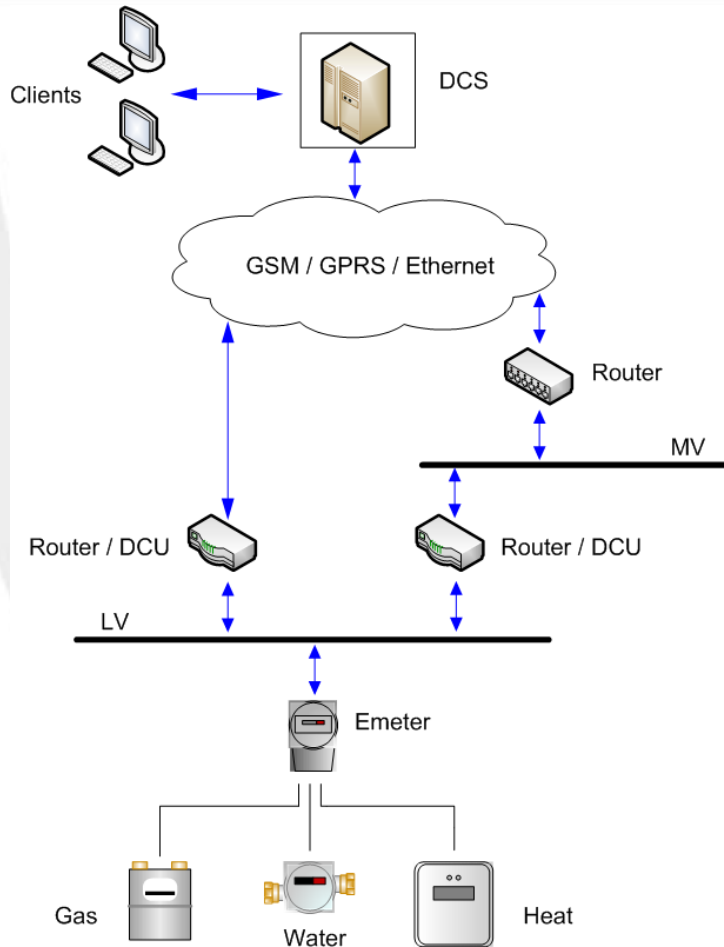

- Current technologies used on LV:
  - FSK/S-FSK (low data rate, sensible to narrowband noise)
  - DCSK (low data rate, large bandwidth required)
- No standards for MV communications
- New applications required by the market
- Increasing demand for higher data rates

# PLC Solution Requirements

- Narrowband (CENELEC limitations: 3 – 148,5 kHz)
- EMC requirements
- Bi-directional communications
- Noise proof
- Repetition technique
- Cross-talk management
- Adaptive to grid topology changes
- 3-phase communications
- High data rates (>10 kbps)
- Auto-discovery services
- Multi-protocol support (TCP/IP, DLMS/COSEM, SML...)
- Secure data transmission
- Low cost (BOM < 5 Euros)

# OFDM Benefits

- AMI systems benefits
  - More detailed profiles and energy quality information
  - Online communication with meters
  - Remote meters firmware update via PLC
  - Instant alarms notification
- Integration of end devices into the IP network
  - Routing-only architecture possible
  - Well-defined protocols and services
  - Less interoperability and interconnectivity problems
  - Existing network management systems
- New applications
  - Security systems
  - Control systems
- Future proof
  - Ready for new market demands

*add new tech to your business!*



# ADD GRUP Solution

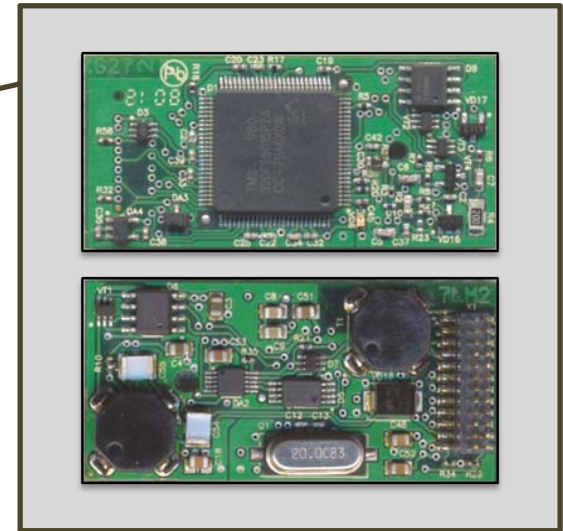
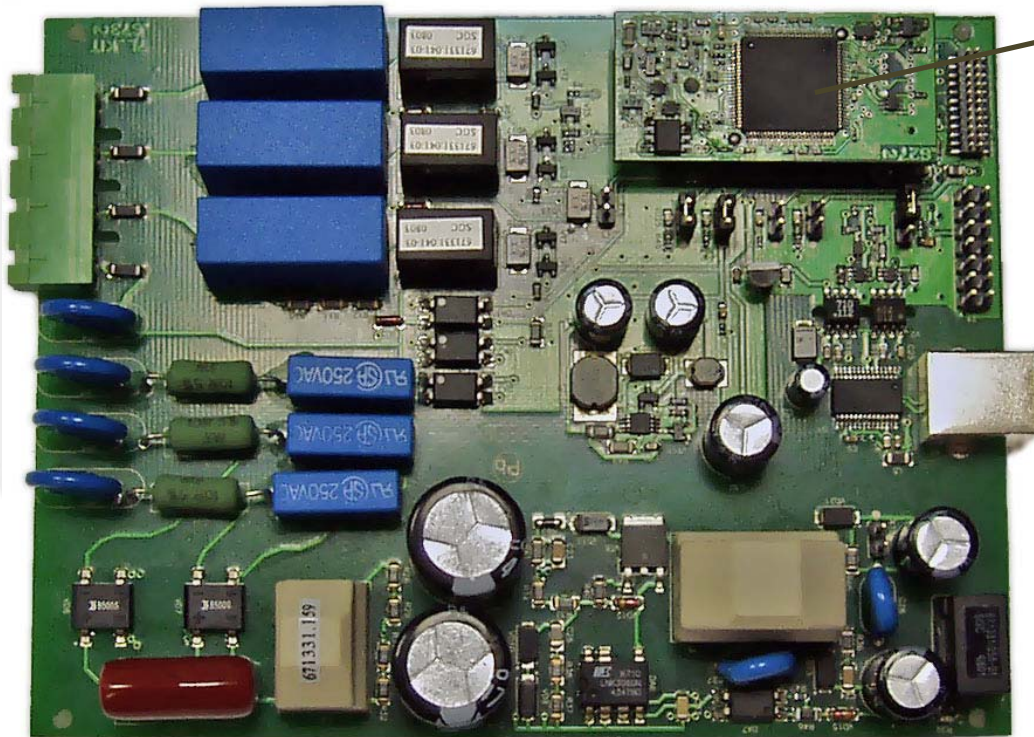

Module Dimensions:  
(L x W x H), mm:  
46 x 22 x 13

Powered by



# ADDM-7LM Block Diagram

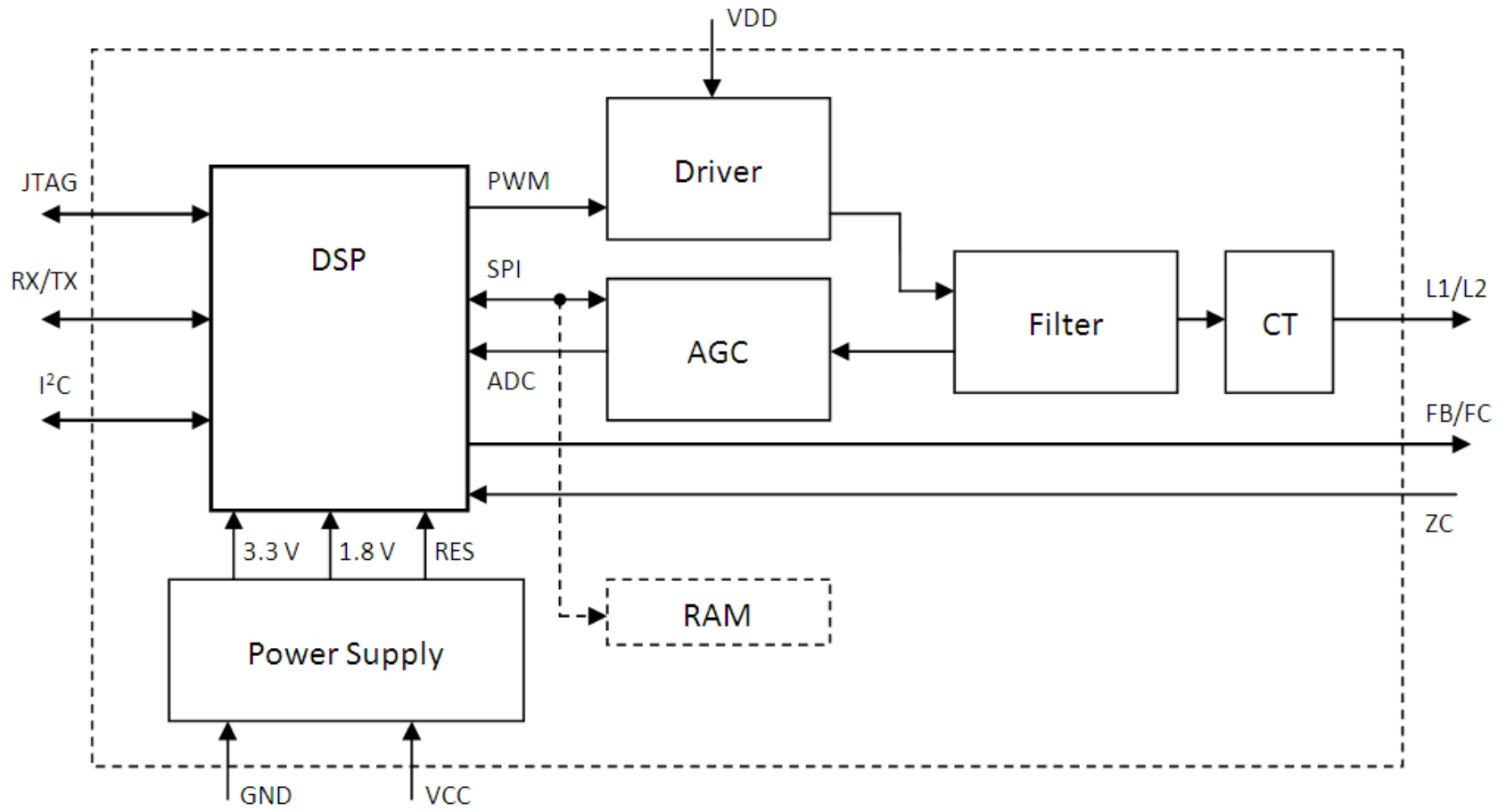

# ADDM-7LM Features (1)

- High performance 32-bit DSP (TMS320F28™)
- Operating frequency range 24 – 94.5 kHz (CENELEC A-band)
- Data rates up to 76,8 kbps for one mains phase (up to 230 kbps for 3-phase communications)
- Transmission with OFDM and FEC
- OFDM performed by complex FFT (128 points)
- Number of used carriers from 12 to 48
- Freely configurable carriers in the operating frequency range
- Flexible carrier notching
- Carriers interval 1500 Hz
- Differential phase modulation technique (DPSK 2/4/8/16)
- Cyclic prefix as guard interval

# ADDM-7LM Features (2)

- Convolutional encoder / Viterbi decoder (constraint length 5, rates 1/2, 2/3 and 3/4)
- Bit interleaving for noise effects reduction
- 32-bit CRC for error detection
- Data randomization for uniform power distribution
- Automatic Gain Control
- Zero-crossing synchronized transmission
- Integrated MAC layer with auto-discovery and repetition mechanism
- Integrated LLC layer IEEE 802.2 type 1
- UART or I<sup>2</sup>C host interface
- Easy integration into any devices of the AMM/AMR systems
- Compatible to Standards EN 50065 (CENELEC), IEC 61000-3

# Transmission Technique

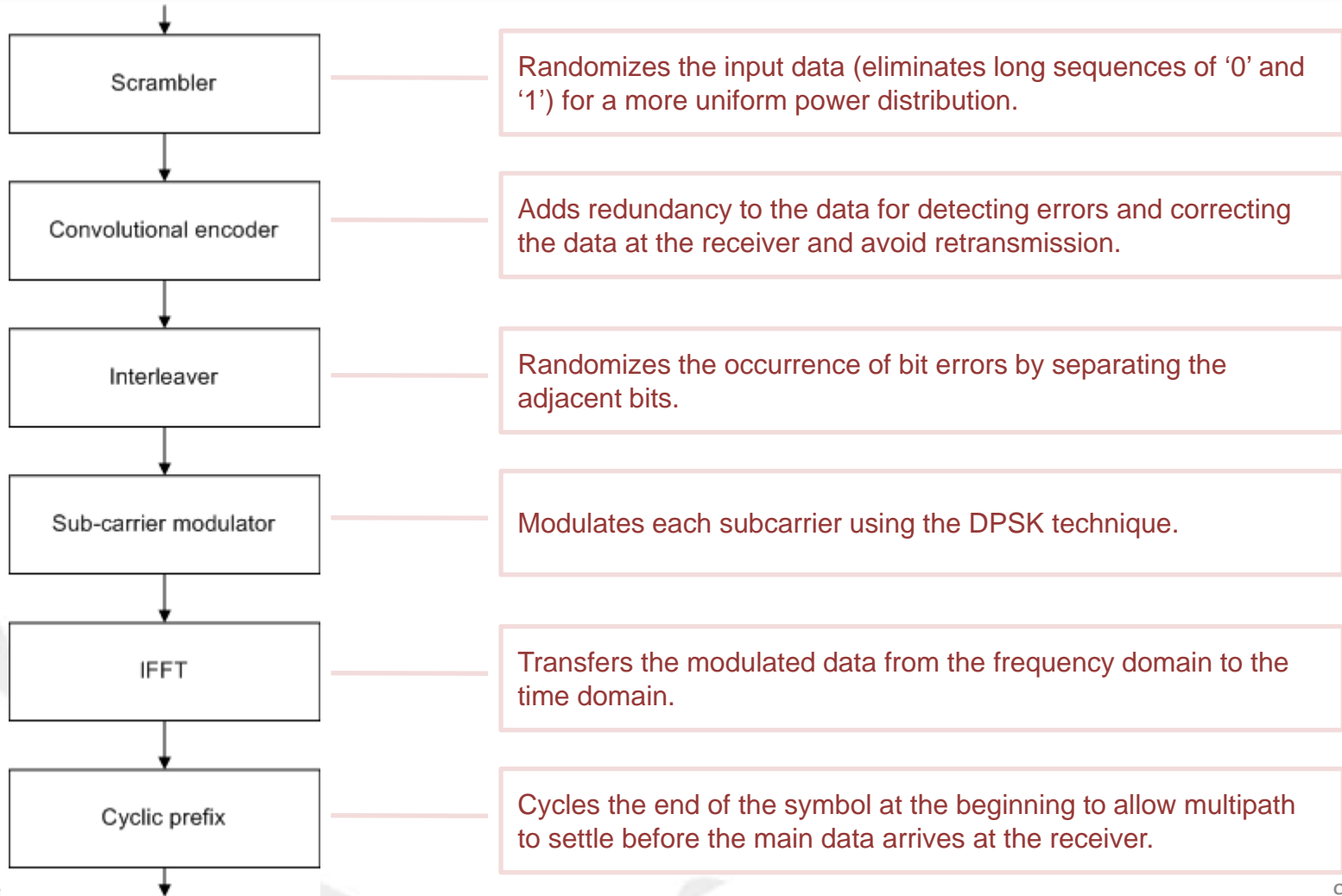

# LV Transmission Windows

- Uses the low noise part of mains voltage
- No inter-phase interference

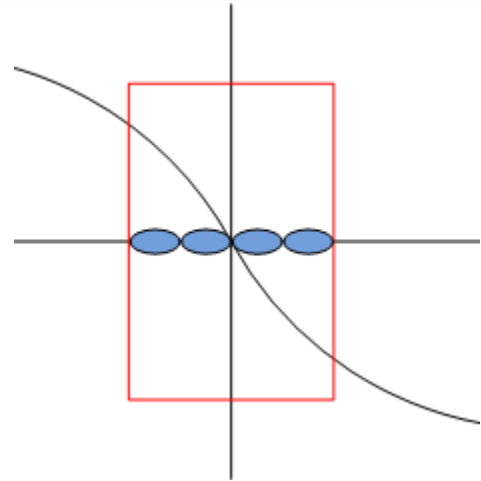
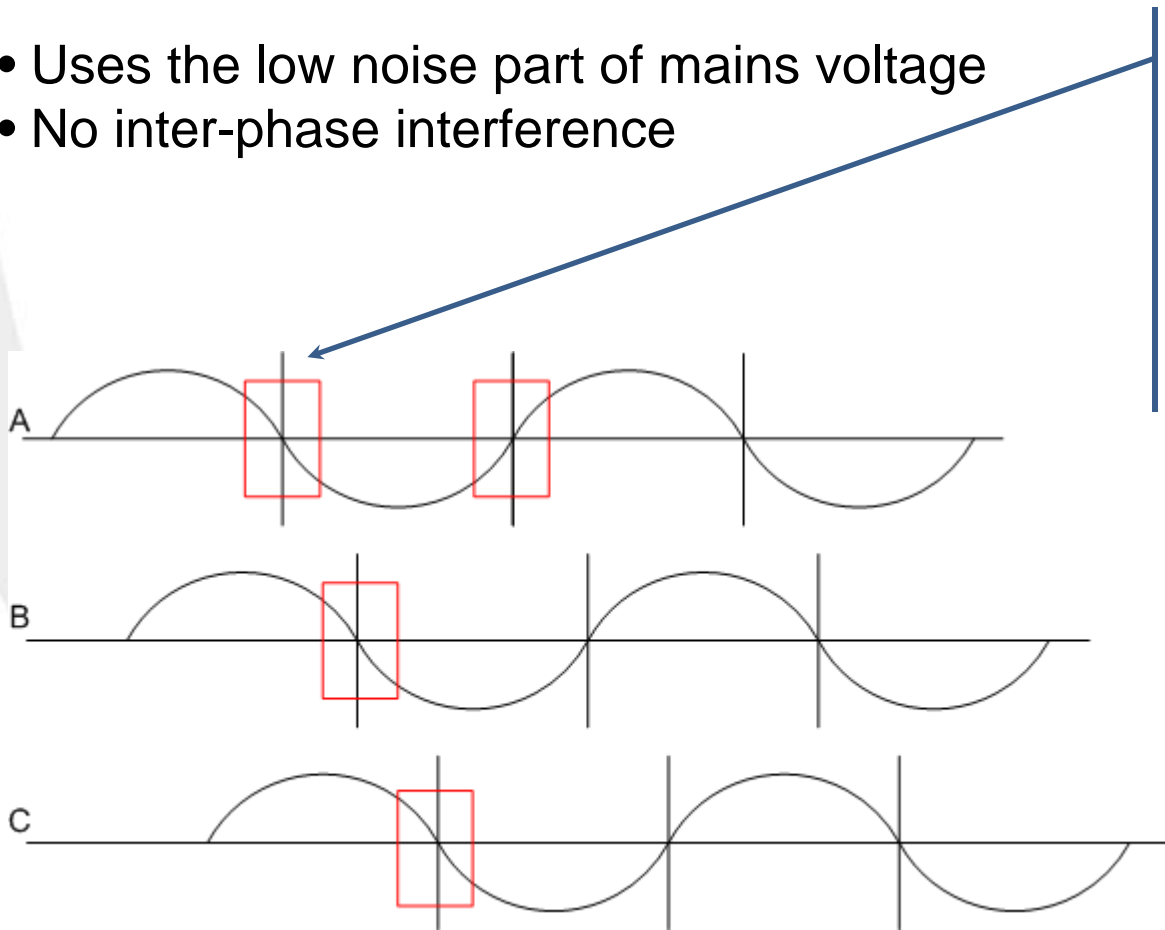

4 OFDM symbols transmitted in one window on mains phase zero-crossing (for 50 Hz)

# Data Rates

Depending on the modulation scheme and coding options the following calculations may be presented for 48 subcarriers used:

	DBPSK		DQPSK		D8PSK		D16PSK	
	FEC		FEC		FEC		FEC	
	1/2	-	1/2	-	1/2	-	1/2	-
<b>Information bits per subcarrier</b>	0,5	1	1	2	1,5	3	2	4
<b>Information bits per symbol</b>	24	48	48	96	72	144	96	192
<b>Raw data rate for LV 1-phase, kbps</b>	9,6	19,2	19,2	38,4	28,8	57,6	38,4	76,8
<b>Raw data rate for LV 3-phases, kbps</b>	28,8	36,6	36,6	115,2	86,4	172,8	115,2	230,4

# Typical Applications

Any applications where data transmission over low voltage power line is necessary, like:

- Metering (AMM/AMR systems)
- Electric quality monitoring
- Energy management
- Security systems
- Control systems
- Home automation

# AMM Application

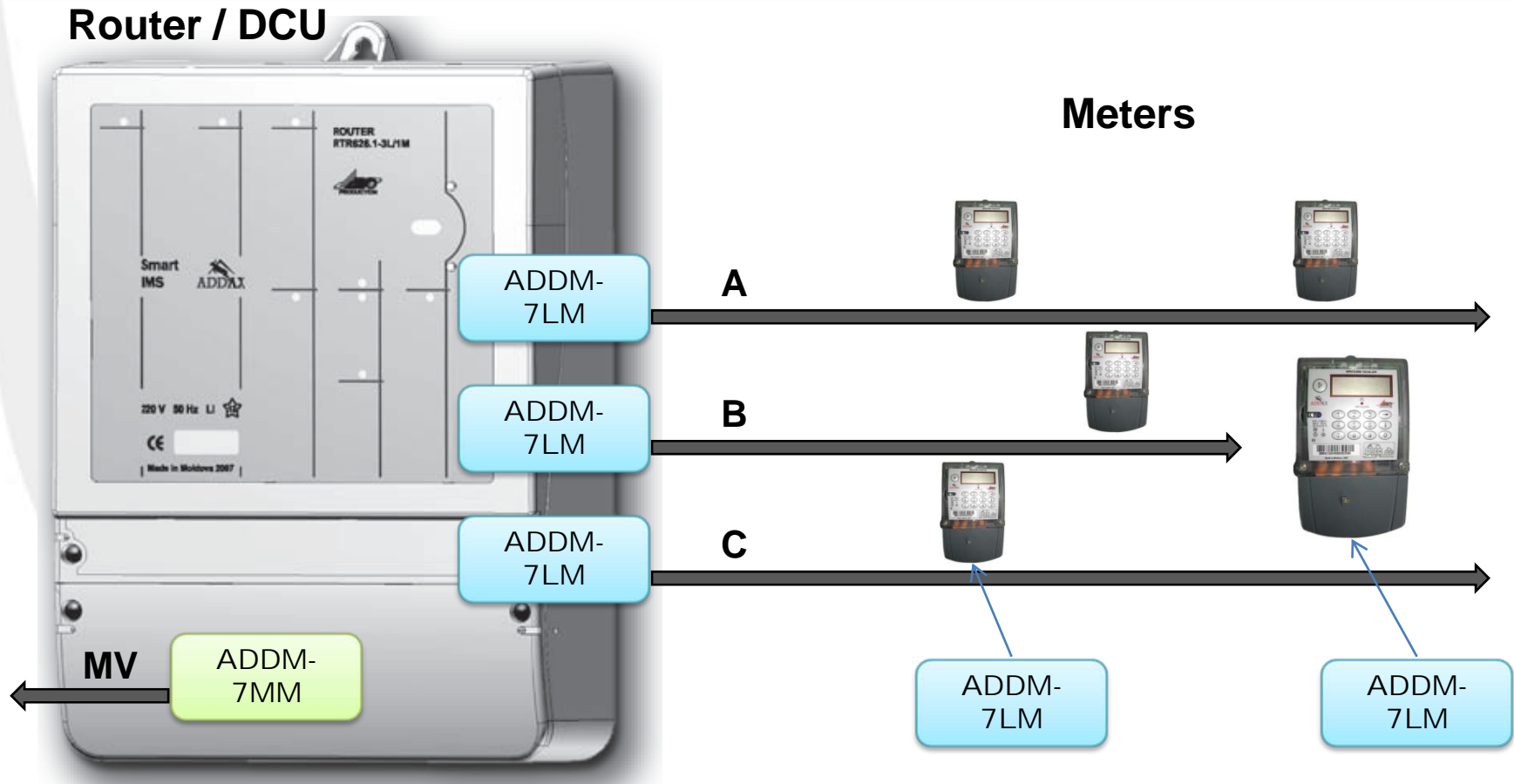

# Objective Achieved

- All PLC issues addressed:
  - Homogenous techniques and protocols used on LV and MV
  - Robust high speed communication
  - Bi-directional 3-phase communication
  - Auto-discovery mechanisms
  - Repetition technique
  - Cross-talk management
- Convergence with other IEEE 802 standards
- With TCP/IP stack - from the shelf implementations for:
  - Addressing and Routing
  - QoS
  - Security
  - Network management
- Flexible to different modulation techniques and protocols
- Low cost and future proof solution

# Thank you for attention!

Visit [www.addgrup.com](http://www.addgrup.com) for more info.